

Semiconductor Optical Amplifier Devices Datasheet

1. Product information

Part Number: SOAD

Product Description: The Semiconductor Optical Amplifier Devices at 1550nm are designed by using a high quality angled SOA chip and a TEC which can assure a stable amplified output for a large dynamic input signal. The devices are available in a standard, 14-pin butterfly package at the 1550nm bands. The SOA devices have high optical gain, high saturation output power, low polarization dependent loss, low noise figure and broad wavelength range. Polarization type:Polarization insensitive,Fiber type:PM fiber, Pigtail type:900um loose tube,Input and output fiber length:100cm,With FC/APC connector.The products are Telcordia GR-468 qualified, and in compliance with RoHS requirement.

Applications:

- Loss compensation for fiberoptic connection and switch
- WDM fiberoptic networks
- 100G fiberoptic data center

Features:

- Wide Optical Bandwidth
- High saturation output power
- Low polarization sensitivity
- Built-in TEC and optical isolator
- Low gain ripple and NF

Reliability: Telcordia GR-468. RoHS



2. Revision History

Rev.	Notes	Prepared by	Audited by	Approved by	Date
V0	Initial release	LX-xin	PPD	Reg	2018-08-07

3. Performance Specifications

Absolute Maximum Ratings

Stresses in excess of the absolute maximum ratings can cause permanent damage to the device. These are absolute stress ratings only. Functional operation of the device is not implied at these or any other conditions in excess of those given in the operational sections of the data sheet. Exposure to absolute maximum ratings for extended periods can adversely affect device reliability.

Parameter	Symbol	Condition	Min.	Typical	Max.	Unit
Storage temperature	T _S	-	-40	-	85	°C
Operating case temperature	T _{op}	-	-20	-	70	°C
Forward Current	I _F	-	-	-	600	mA
SOA Reverse Voltage	V _R	-	-	-	2.5	V
TEC current	I _{TEC}	-	-	1.0	1.5	A
TEC voltage	V _{TEC}	-	-	2.8	3.5	V

Optical Characteristics (at 25 °C laser temperature)

Parameter	Symbol	Condition	Min.	Typical	Max.	Unit
Center Wavelength	λ_c	TL=15~35°C CW	1530	1550	1570	nm
3dB Optical Bandwidth	$\Delta\lambda_{3dB}$	-	50	-	-	nm
3dB saturation output power	P _{sat}	CW	8	10	-	dBm
Small Signal Gain@ λ_c (Over C-Band @ P _{in} = -25 dBm)	G _{max}	-	13	16	-	dB
Gain Ripple with Respect to λ	ΔG	-	-	0.5	1.0	dB
Noise Figure	NF	-	-	10	-	dB
Polarization Dependent Gain	PDG	-	-	2.0	3.0	dB
Optical Isolation	ISO	-	30	-	-	dB

Electrical Characteristics (at 25 °C laser temperature)

Parameter	Symbol	Condition	Min.	Typical	Max.	Unit
Operating current	I _{op}	-	-	350	600	mA
TEC set temperature	T _s	-	15	-	35	°C
Thermistor Current	I _{TC}	-	10	-	100	μA
Thermistor Resistance	R _{TH}	T _L = 25 °C	9.5	10	10.5	KΩ
Thermistor temperature	-	-	-	-	100	°C

Fiber Pigtail Specifications

Parameters	Description
Fiber Type	SMF-28e
Jacket Type	900μm tight tube
Pigtail Length	1.0±0.1m
Connector Type	FC/APC

4. Package drawing (Mechanical Dimensions):

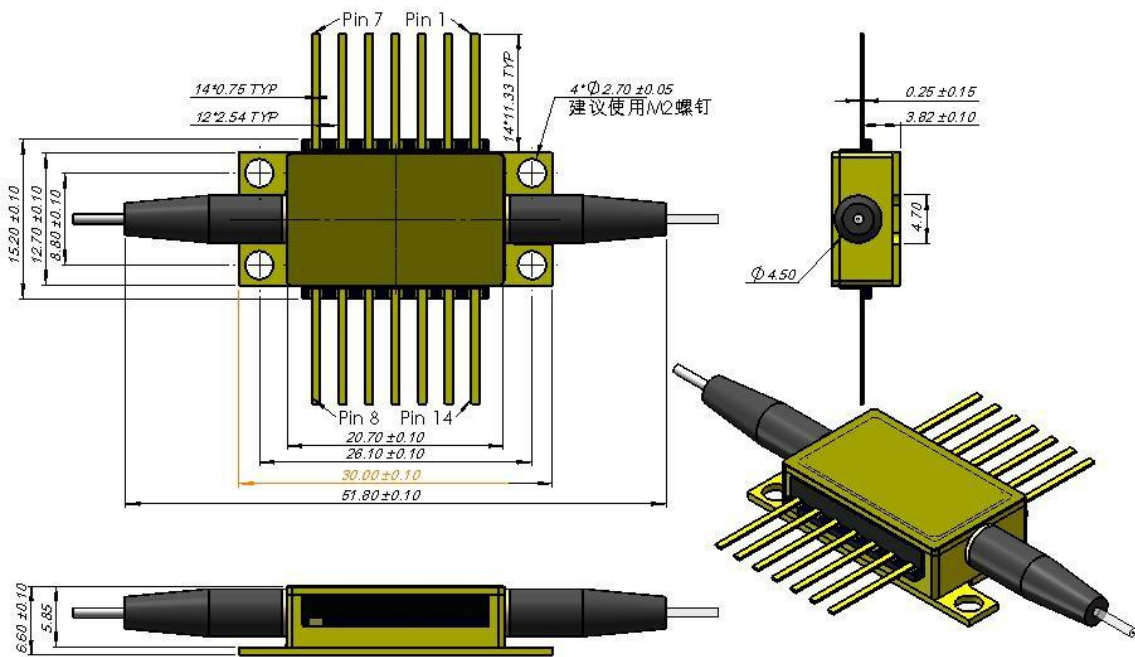

Dimensions are in millimeters.

5. Pin Assignments:

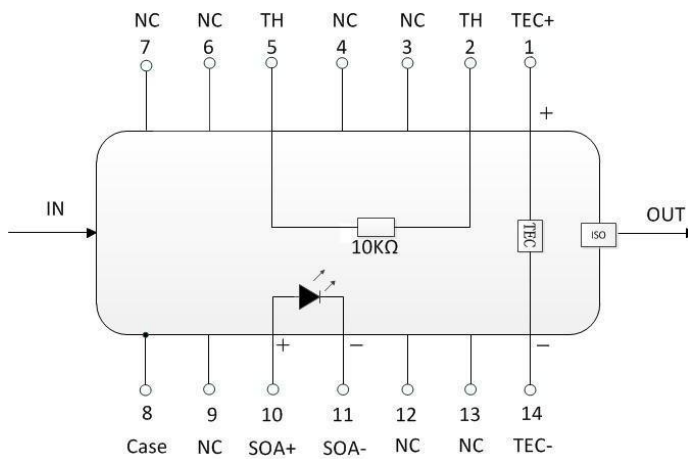

1	Thermoelectric Cooler (+)
2	Thermistor
3	NC
4	NC
5	Thermistor
6	NC
7	NC
8	Case Ground
9	NC
10	SOA Anode (+)
11	SOA Cathode (-)
12	NC
13	NC
14	Thermoelectric Cooler (-)

6. Test Report: The test report should be provided when the products are delivered. Following characteristic test data should be included: -Optical Output Power, Center Wavelength, Key parameter, Pin Assignments.

7. Packaging: Vacuumize anti-static plastic package. Following items should be indicated on the outer packaging surface:

- Product Name
- Product Number